



TWO COMPARTMENT SINKS W/ NO DRAINBOARD AND THREE SIDED CROSS BRACING

PROJECT#: _____

ITEM# _____

MODEL# _____

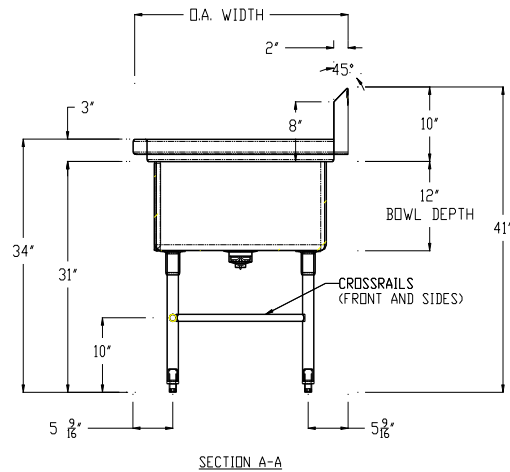
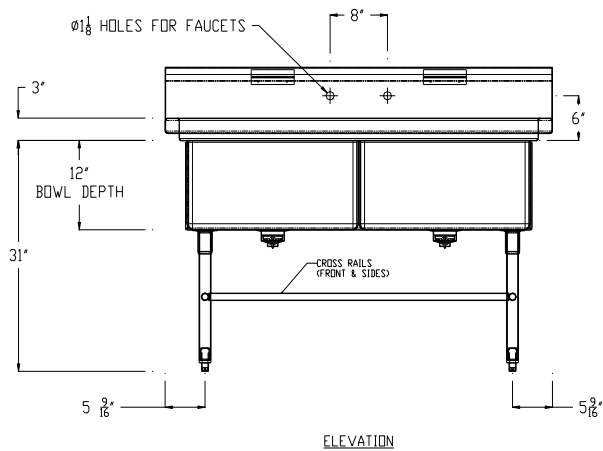
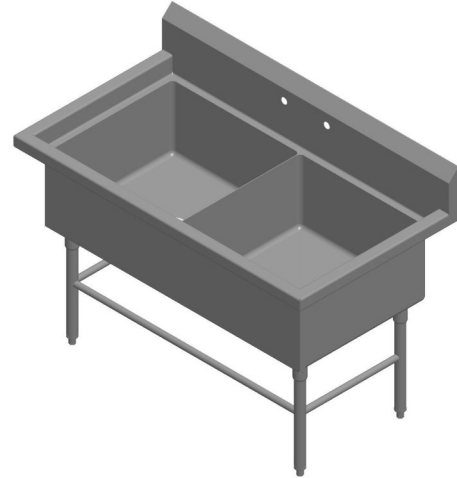
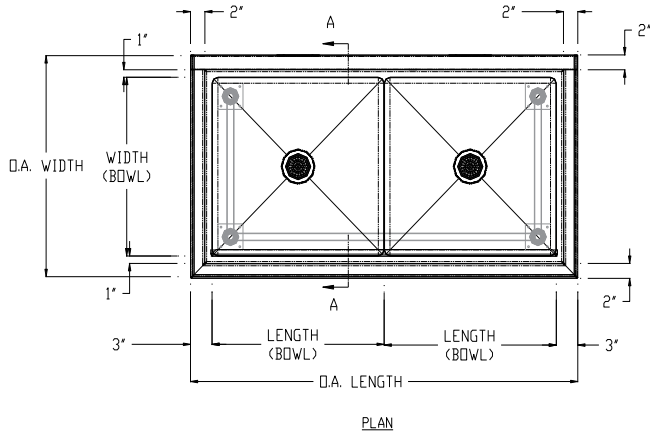

TWO COMPARTMENT SINKS W/ NO DRAINBOARD & THREE SIDED CROSS BRACING							
MODEL#	QTY	PRODUCT DIMENSIONS (INCHES)					SHIPPING WEIGHT (LBS)
		LENGTH (BOWL)	WIDTH (BOWL)	O.A. LENGTH	O.A. WIDTH	OVERALL HEIGHT	
C-2-1618-CC		16"	18"	38"	24"	41"	91
C-2-1824-CC		18"	24"	42"	30"	41"	112
C-2-2424-CC		24"	24"	54"	30"	41"	117
C-2-2030-CC		20"	30"	46"	36"	41"	142

SINK SPECIFICATIONS:

TOP: 16 GA. 300 Series Stainless Steel

SINK BOWLS: 16 GA. 300 Series Stainless Steel

CROSS BRACING: 1" Diameter Stainless Steel Welded To Legs

LEGS: 1 5/8" Diameter Stainless Steel Tubing

CONSTRUCTION:

- ◆ Fully welded, Seamless, Polished to #4 Finish
- ◆ Euro Edge
- ◆ S/S Adjustable Bullet Feet
- ◆ Crumb Cup Drain 1 1/2" IPS
- ◆ 8" On Center Faucet Holes
- ◆ Ships with (2) Wall Mount "Z" Clips